

Coaxial Analog 1550nm FP-LD Module with Pigtail

Description

LT5Fxx series Coaxial Laser use InGaAsP/InP MQW chip. The FP integrated an InGaAs monitor PD, it can be used with appropriate feedback control circuitry to set optical power level for the FP laser, As the current changed above the threshold, the optical power will change accordingly.

They are widely used in CATV or CDMA system. The laser diode is mounted into a coaxial package with single mode fiber pigtail. FC/UPC, FC/APC, SC/UPC or SC/APC connector can be selected.

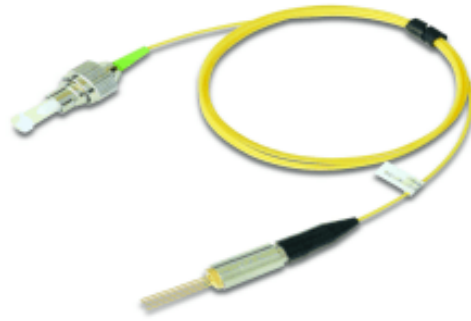

Features

- 1550 nm transmitter with uncooled FP-LD
- Low noise, low distortion, high linearity
- Coaxial Pigtail Package
- operating temperature range: -20°C to 80°C

Application

- CDMA/GSM transmission system
- WDM system
- Other analog transmission system

Absolute Maximum Ratings^[1]

Parameter	Symbol	Min	Max	Units	Notes
Reverse Voltage(LD)	V_{RL}	---	2	V	
Forward Current(LD)	I_{FL}	---	120	mA	
Reverse Voltage(MPD)	V_{RMP}	---	15	V	
Forward Current(MPD)	I_{FMP}	---	2	mA	
Operating Temperature ^[1]	T_C	-20	+80	□	Case temperature
Storage Temperature	T_{STG}	-40	+85	□	Ambient temperature
Relative Humidity	RH	---	80	%	
Lead Soldering Temperature/Time	T_S	---	260/10	□/S	
Fiber Yield Strength		---	1	kgf	
Fiber Bend Radius		30	---	mm	

Note 1: Beyond the scope of absolute maximum ratings can cause permanent damage to the device. If it has been a

long time to use the device in the absolute maximum ratings may affect device reliability.

Electric and Optical Characteristics

(All measurements are at Case temperature of 25±3℃ @1550nm unless stated otherwise.)

Parameter	Symbol	Min	Typical	Max	Units	Notes
Fiber Output Power ^[1]	P _o	1.5	---	3.6	mW	CW, I _f =I _{th} +20mA
Slope Efficiency	η	0.075	---	0.18	W/A	CW
Center Wavelength	λ	1530	1550	1570	nm	CW, I _f =I _{th} +20mA
Spectral Width(RMS -20dB)	Δλ	---	2	5	nm	CW, I _f =I _{th} +20mA
Modulation Bandwidth	BW	2.5	---	---	GHz	-3dB
		5.0	---	---		-3dB, with FPC
Tracking Error	TE	-1.5	---	1.5	dB	I _M hold@P _o =2mW,25°C,CW, T _c = -20 ~+80℃
Optical Isolation	ISO	30	---	---	dB	With Single Stage Isolator
		45	---	---		With Double Stage Isolator
Return Loss	RL	40	---	---	dB	SC/UPC or FC/UPC connector
		50	---	---		SC/APC or FC/APC connector
Threshold Current	I _{th}	---	8	15	mA	CW
Operating Voltage	V _F	---	1.2	1.6	V	CW
Monitor Current	I _M	100	---	1500	μA	CW, I _f =I _{th} +20mA, V _{RMP} =1V
Monitor Dark Current	I _D	---	---	100	nA	CW, V _{RMP} =5V
Photodiode Capacitance	C	---	---	10	pF	V _{RMP} =5V, f=1MHz
3rd Order Inter-modulation Distortion	IMD3	---	-65	-60	dBc	[2],CW
		---	---	-55		[3],CW
Relative Intensity Noise	RIN	---	---	-135	dB/Hz	CW
Pigtail Length	L	900	1000	1100	mm	Outline Dimensions [X]

Notes: [1]: For 2~3.6mW products by increasing the operating current to achieve 4mW products.

[2]:Test conditions: P_f =2.0 mW, T_c=25℃,2 channel modulated carriers 800MHz and 801MHz, Zero link loss, RF 0dBm input and output tested.

[3] Test conditions: P_f =2.0 mW, T_c=25℃,2 channel modulated carriers 1.9GHz and 1.901GHz, Zero link loss, OMI=20% tested.

Pigtail parameters

Parameter	Symbol
Optical connector	FC/UPC,FC/APC, SC/UPC or SC/APC (IEC874/7)
Mode field diameter	9.5±1um
Cladding diameter	125±2um
Outermost Jacket	900±100um
Jacket color	Yellow or White

LT5Fxx series Coaxial Module

Pigtail Length	1.0±0.1m
----------------	----------

Outline Dimensions

All dimensions are ±0.1mm unless otherwise specified (Unit: mm). For detail information please contact LinkPhotonic.

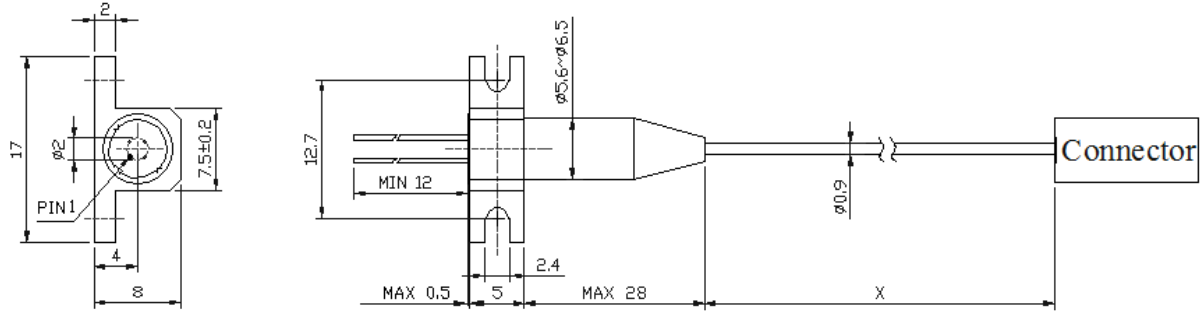

Package 1 without FPC

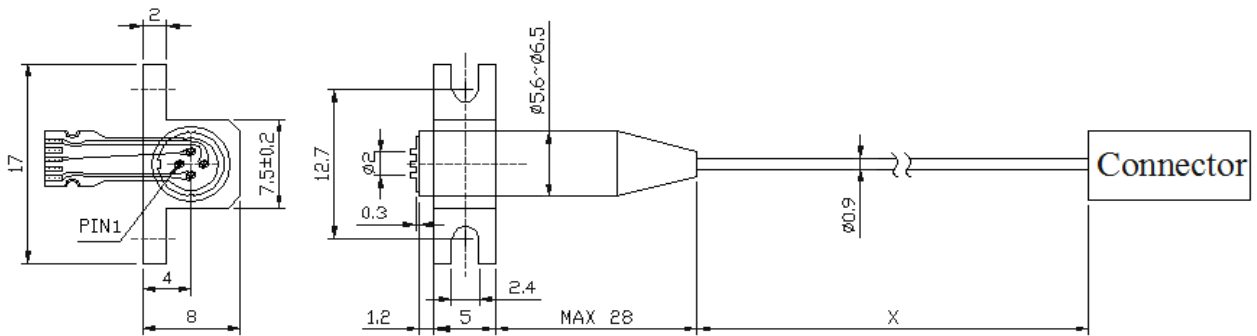

Package 1 with FPC

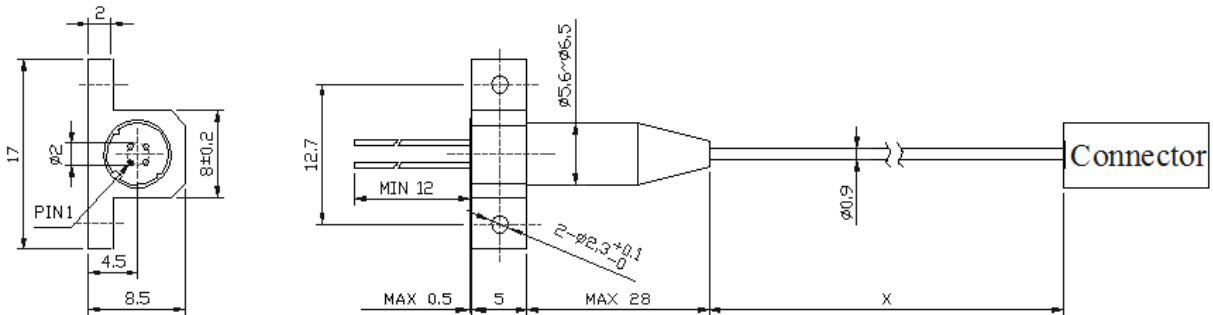

Package 2 without FPC

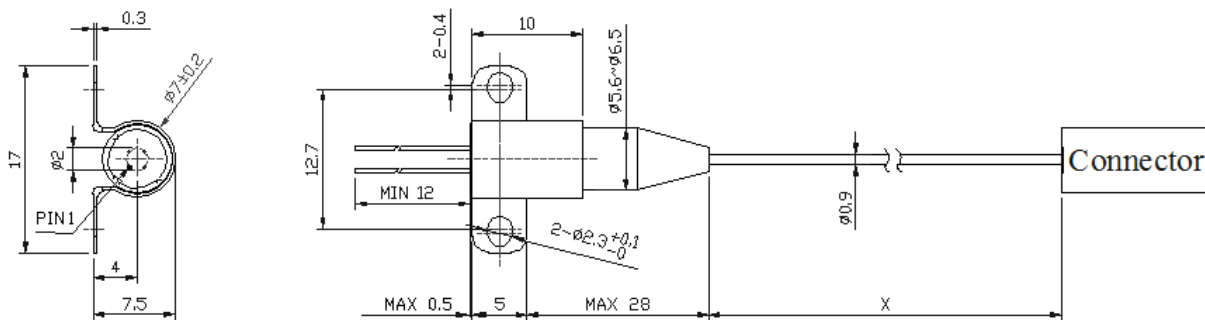

Package 3 without FPC

Outline of FPC and Pad Descriptions

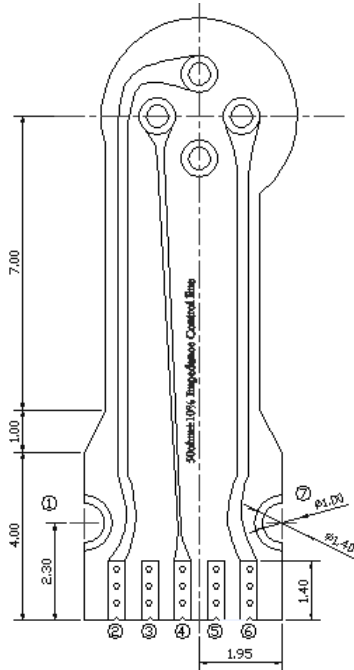

Top Side

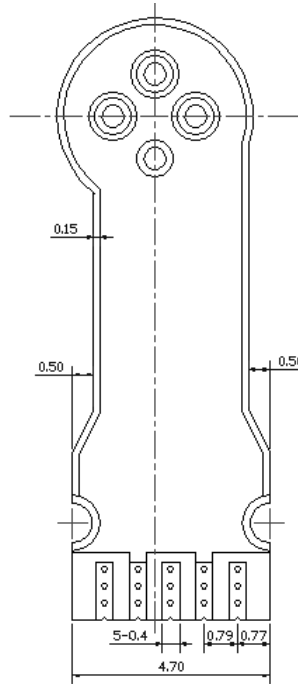

Bottom Side

Pin	
1	GND (LD+/Case)
2	PD-
3	GND (LD+/Case)
4	LD- (RF in)
5	GND (LD+/Case)
6	PD+
7	GND (LD+/Case)

LD Pin Assignment

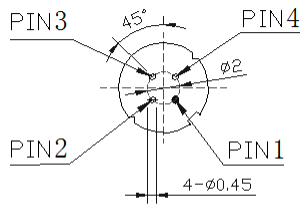

Bottom View

Pin	
1	LD + /CASE
2	LD-
3	PD-
4	PD+

LD Pin Direction:

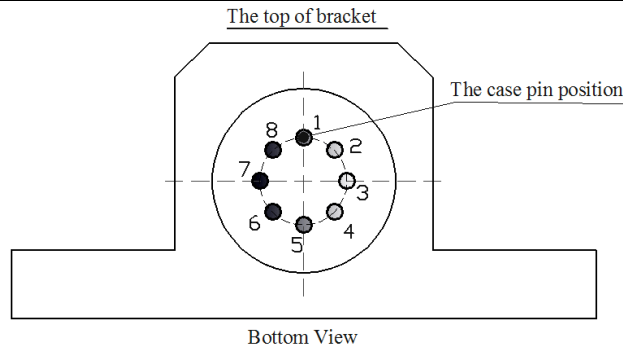

Note: 0: Any **direction** 9: with FPC

Precautions

Semiconductor chips are sensitive to electro-static damage. The module shall be packed with antistatic material for transportation. The working station and operators shall be grounded. Switching transients can cause electrical overstress (EOS) damage to the chips. EOS be may resulted from improper ESD handling, improper power sequencing, a faulty power supply or an intermittent connection.

- a. Operators should always use antistatic bands and clothing, electric conductive shoes, and other safety appliances while at work are highly recommended.
- b. Humidity in working environment should be controlled equal or above 40 percent RH.
- c. It is recommended that grounding mats be placed on the surfaces of assembly line workbench and the surrounding floor in working area, etc.
- d. When mounting this product in other parts or materials which can be electrically charged (printed wiring boards, plastic products, etc.), pay close attention to the static electricity in those parts.ESD may damage the product.

Ordering Information

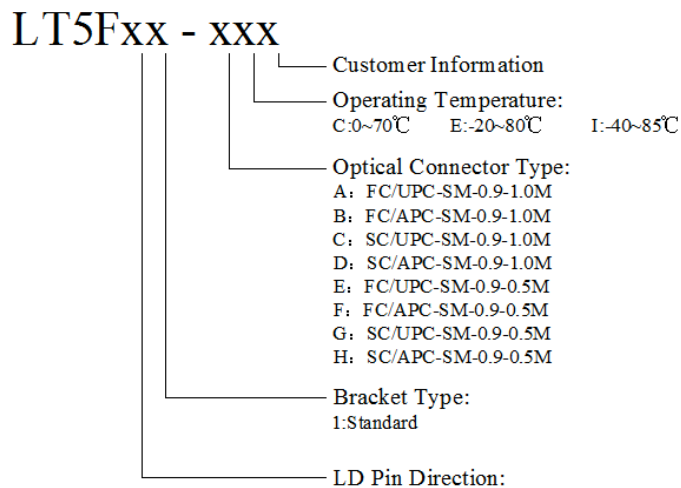

Statement

The information provided herein is believed to be reliable, LinkPhotonic assumes no liability for

LT5Fxx series Coaxial Module

inaccuracies or omissions. LinkPhotonic assumes no responsibility for the use of this information, and all such information shall be entirely at the user's own risk. Prices and specifications are subject to change without notice. No patent rights or licenses to any of the circuits described herein are implied or granted to any third party. LinkPhotonic does not authorize or warranty any LinkPhotonic product for use in life-support devices and/or systems. Copyright © 2014 LinkPhotonic Inc. All rights reserved.