

Coaxial Analog PIN Detector Module with Pigtail

Description

LH1xxx series are high responsibility and high linearity PIN photodiodes.

The products features: Low capacitance, low dark current and high optical return loss. They are widely used in instrument at 1260-1620nm operating wavelength for receiver. This device is mounted into a coaxial package integrated with a single mode or multi-mode fiber pigtail, and FC, SC, ST or LC Connector.

Features

- High responsibility 0.85A/W
- High linearity InGaAs PIN detector
- Low distortion, high bandwidth
- High reliability coaxial pigtail package
- FC, SC or ST Connector can be selected



Application

- Receiver For CATV/CDMA
- EDFA Monitors and FTTX Networks
- Analog Linear receiver Systems
- Receiver for Instrument

Absolute Maximum Ratings^[1]

Parameter	Symbol	Min	Max	Units	Notes
PIN Reverse Voltage	V_R	---	25	V	
PIN Forward Current	I_R	---	10	mA	
Fiber Input Power	P_{IN}	---	10	dBm	
Operating Temperature	T_C	-40	+85	□	Case temperature
Storage Temperature	T_{STG}	-40	+85	□	Ambient temperature
Relative Humidity	RH	---	80	%	
Lead Soldering Temperature	T_S	---	260	□	
Lead Soldering Time		---	10	S	$T_S=260$ □
Fiber Yield Strength		---	1	kgf	
Fiber Bend Radius		30	---	mm	

Note 1: Beyond the scope of absolute maximum ratings can cause permanent damage to the device. If it has been a long time to use the device in the absolute maximum ratings may affect device reliability.

Electric and Optical Characteristics

(All measurements are at Case temperature of $25 \pm 3^\circ\text{C}$, $V_R=12\text{V}@1310\text{nm}$ unless stated otherwise.)

Parameter	Symbol	Min	Typical	Max	Units	Notes
Operating Wavelength	λ	1260	---	1620	nm	
Supply Voltage	V_S	---	-12	-5	V	
Responsibility	R	0.8	0.85	---	A/W	$V_R=5\text{v}, 1310\text{nm}$
		0.85	0.9	---		$V_R=5\text{v}, 1550\text{nm}$
		0.85	0.9	---		$V_R=5\text{v}, 1310\text{nm}, \text{customize}$
		0.9	0.95	---		$V_R=5\text{v}, 1550\text{nm}, \text{customize}$
Active Area	Φ	---	75	---	μm	
Return Loss	RL	---	---	-35	dB	SM fiber or MM fiber
		---	---	-45		customize
Modulation Bandwidth	BW	3.0	---	---	GHz	-3dB, $V_R=12\text{V}$, Pin=0dBm
		5.0	---	---		-3dB, $V_R=12\text{V}$, Pin=0dBm with FPC
Capacitance	C	---	0.4	0.7	pF	$V_R=5\text{v}, f=1\text{MHz}$
Dark Current	I_D	---	---	1.0	nA	$V_R=5\text{v}$
Composite Second Order beat	CSO	---	---	-70	dBc	[2]
Composite Third Order beat	CTB	---	---	-80	dBc	[2]
Pigtail Length	L	900	1000	1100	mm	Outline Dimensions [X]

Notes 2: Two-tone test condition : $f_1=50\text{MHz}$, $f_2=505\text{MHz}$, $f_1 \neq f_2$, $V_R=-12\text{V}$, $P_{\text{avg}}=0\text{dBm}$, $\text{OMI}=0.25$, $R_{\text{load}}=75\Omega$.

Pigtail parameters

Parameter	Symbol
Optical connector	FC/UPC, FC/APC, SC/UPC or SC/APC (IEC874/7)
Mode field diameter	$9.5 \pm 1 \mu\text{m}$
Cladding diameter	$125 \pm 2 \mu\text{m}$
Outermost Jacket	$900 \pm 100 \mu\text{m}$
Jacket color	Yellow or White
Pigtail Length	$1.0 \pm 0.1 \text{m}$

Outline Dimensions

All dimensions are $\pm 0.1\text{mm}$ unless otherwise specified (Unit: mm). For detail information please contact LinkPhotonic.

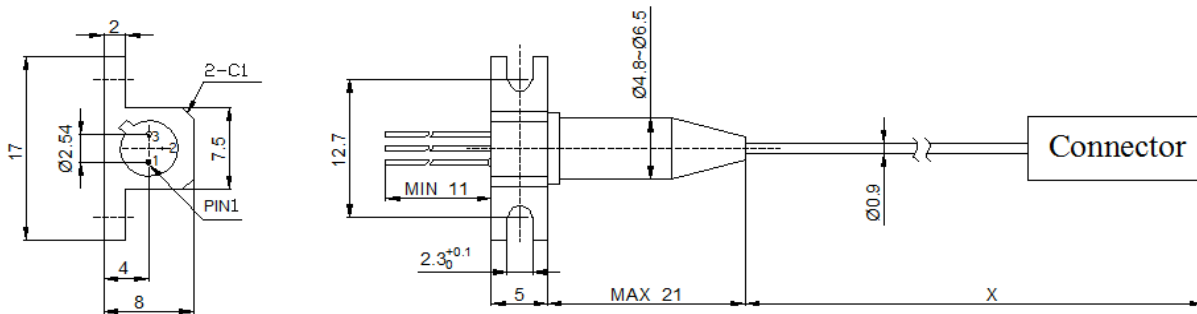

Package 1 without FPC

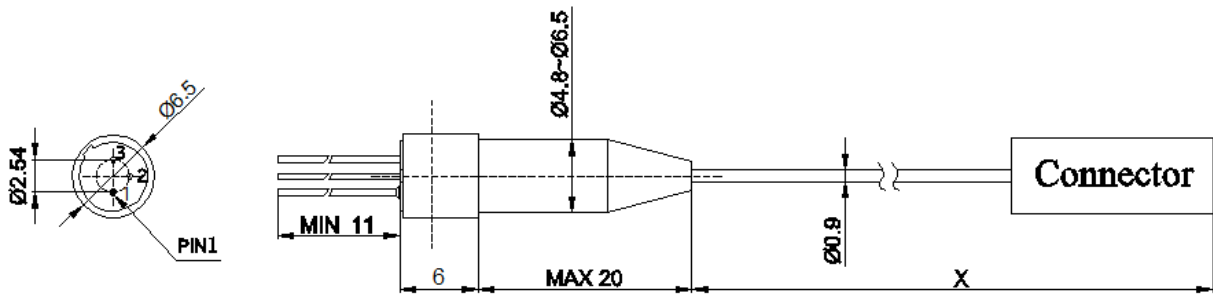

Package 2 without FPC & bracket

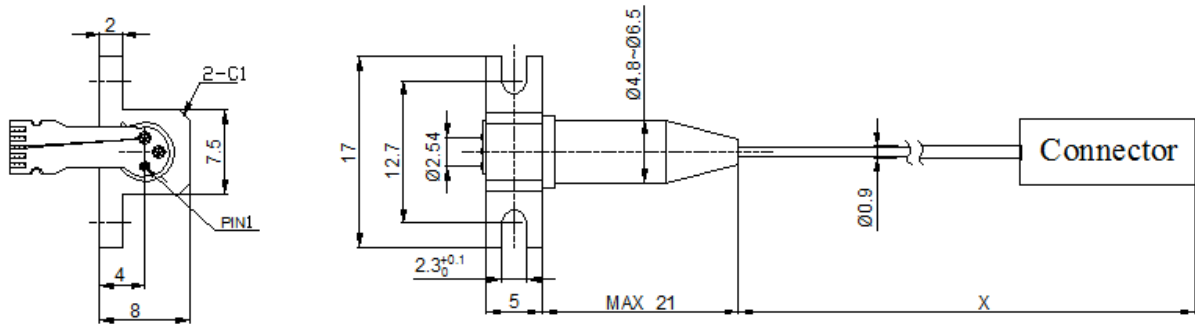

Package 3 with FPC

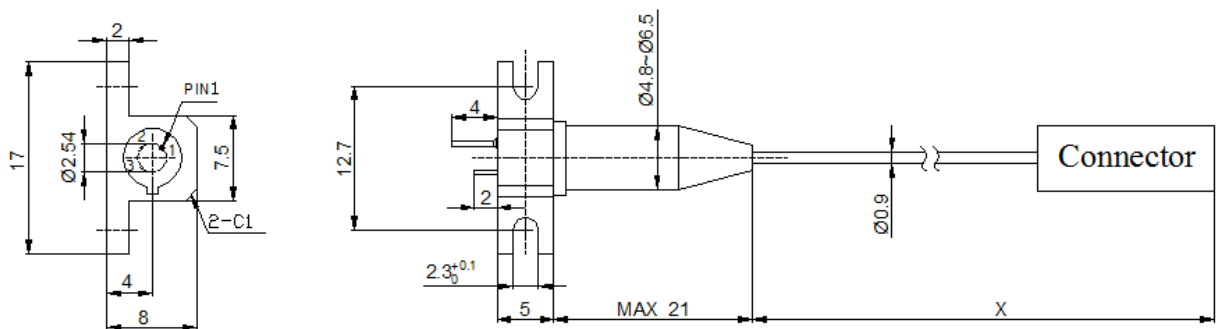

Notes:

1. The length of PIN1 is about 4±0.5mm.
2. The length of PIN1 is about 2±0.5mm.
3. The length of PIN1 is about 2±0.5mm.

Package 4 short pin

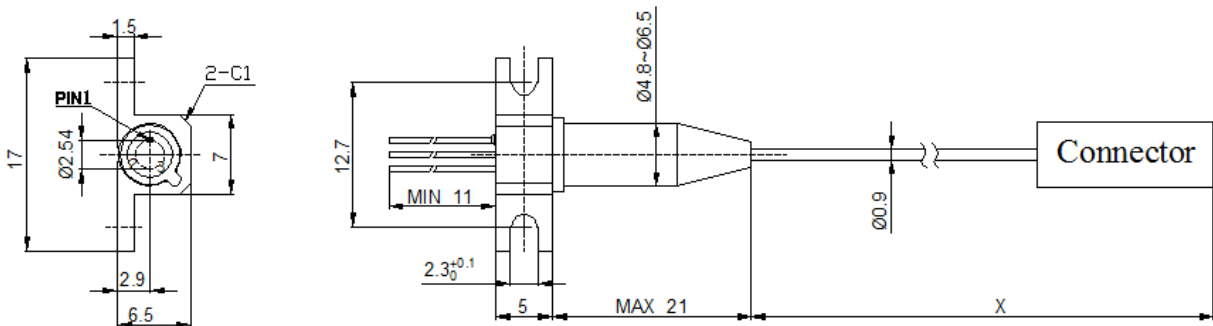

Package 5 small bracket

Outline of FPC and Pad Descriptions

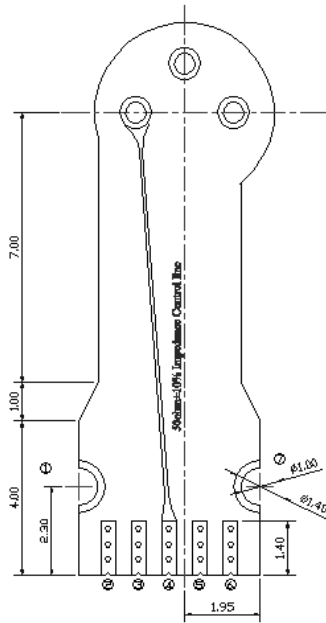

Top Side

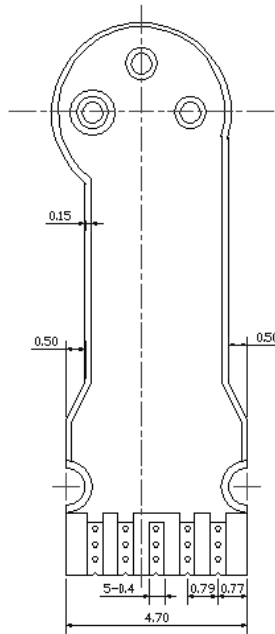

Bottom Side

Pin	
1	GND (PD-/Case)
2	GND (PD-/Case)
3	GND (PD-/Case)
4	PD+ (RF out)
5	GND (PD-/Case)
6	GND (PD-/Case)
7	GND (PD-/Case)

PD Pin Assignment

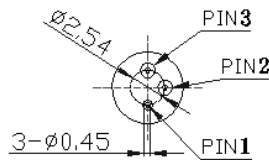

Bottom View

Pin	
1	CASE
2	PD Cathode
3	PD Anode

PD Pin Direction:

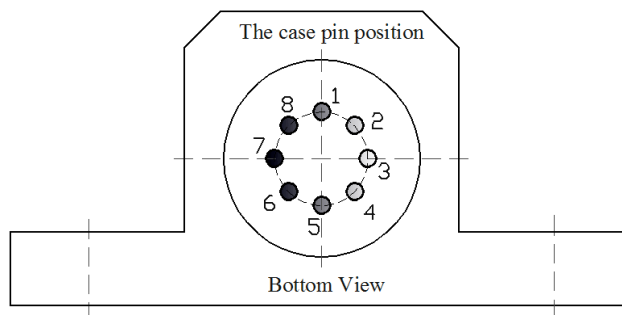

Note: 0: Any **direction**

9: with FPC

Precautions

Semiconductor chips are sensitive to electro-static damage. The module shall be packed with antistatic material for transportation. The working station and operators shall be grounded. Switching transients can cause electrical overstress (EOS) damage to the chips. EOS be may resulted from improper ESD handling, improper power sequencing, a faulty power supply or an intermittent connection.

a. Operators should always use antistatic bands and clothing, electric conductive shoes, and other safety appliances while at work are highly recommended.

b. Humidity in working environment should be controlled equal or above 40 percent RH.

c. It is recommended that grounding mats be placed on the surfaces of assembly line workbench and the surrounding floor in working area, etc.

d. When mounting this product in other parts or materials which can be electrically charged (printed wiring boards, plastic products, etc.), pay close attention to the static electricity in those parts.ESD may damage the product.

Ordering Information

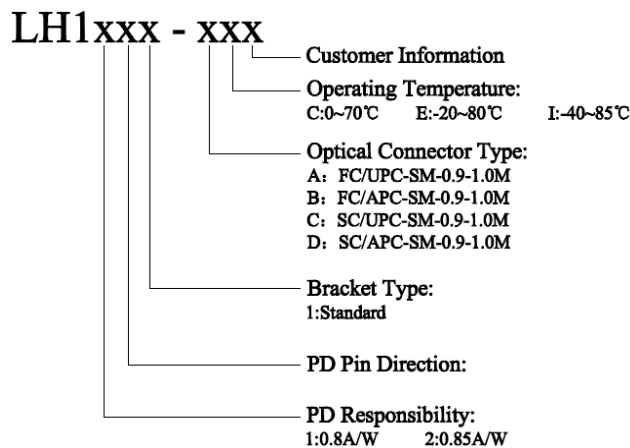

Statement

The information provided herein is believed to be reliable, LinkPhotonic assumes no liability for inaccuracies or omissions. LinkPhotonic assumes no responsibility for the use of this information, and all such information shall be entirely at the user's own risk. Prices and specifications are subject to change without notice. No patent rights or licenses to any of the circuits described herein are implied or granted to any third party. LinkPhotonic does not authorize or warranty any LinkPhotonic product for use in life-support devices and/or systems. Copyright © 2014 LinkPhotonic Inc. All rights reserved.